



Owner's Manual & User's Guide

1 **Primo**



Primo Model Shown
with Stand + Riser

Congratulations!

You are now the owner of a Ciao Bella Pizza Oven.

Warning

- Read and understand instructions prior to assembly and use. Place the Outdoor Oven on a non-combustible surface before use.
 - Always use cooking utensils (peels, brushes and cookware) suitable for wood-fired cooking. The outdoor oven has to be installed on a secure level base prior to use;
 - The recommendation that the pizza oven shall be heated up and the fuel kept red hot for at least 30 min prior to the first cooking on the your pizza;
 - DO NOT OVERHEAT OVEN: Extreme heat can permanently damage the Outdoor Oven. Bring the Outdoor Oven up to temp slowly. Start with a small fire in the center. Once established, move the fire to the LEFT side of the oven. Add small amounts of wood until the Outdoor Oven reaches even, high heat. A good temperature for pizza baking is when the Cooking Stone is 550°F-625°F.
 - NEVER USE CHEMICAL FUEL STARTERS: Only use small kindling to help start your fire. Starting fluids and other fire starters can foul the cooking surface and permanently damage the Outdoor Oven.
 - NEVER USE CHEMICAL CLEANERS: Only clean a cool oven. Only use a metal bristle brush or a damp cloth to clean the Cooking Stone.
 - WARNING! Do not use spirit or petrol for lighting or re-lighting! WARNING! Keep children and pets away WARNING! This barbecue will become very hot, do not move during operation. Use only firefighters complying to EN 1860-3!
 - WARNING! Do not use indoors!
 - Do not use the pizza oven in a confined and/or habitable space e.g. houses, tents, caravans, motor homes, boats. Danger of carbon monoxide poisoning fatality.
- Always inspect your Broom Brush bristles. They should be replaced at anytime you feel they are loose.
 - Broom Brush should be replaced every 6 months. You should dispose your brush evidently.

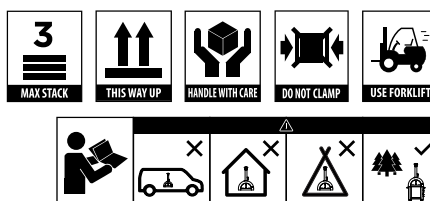

What's in the box?

A) COMPLETE PIZZA OVEN



Accessories

OVEN TOOLKIT

1. Pizza peel
2. Oven broom
3. Pizza server
4. Cutting wheel
5. Log holder

Explosive View & Parts List

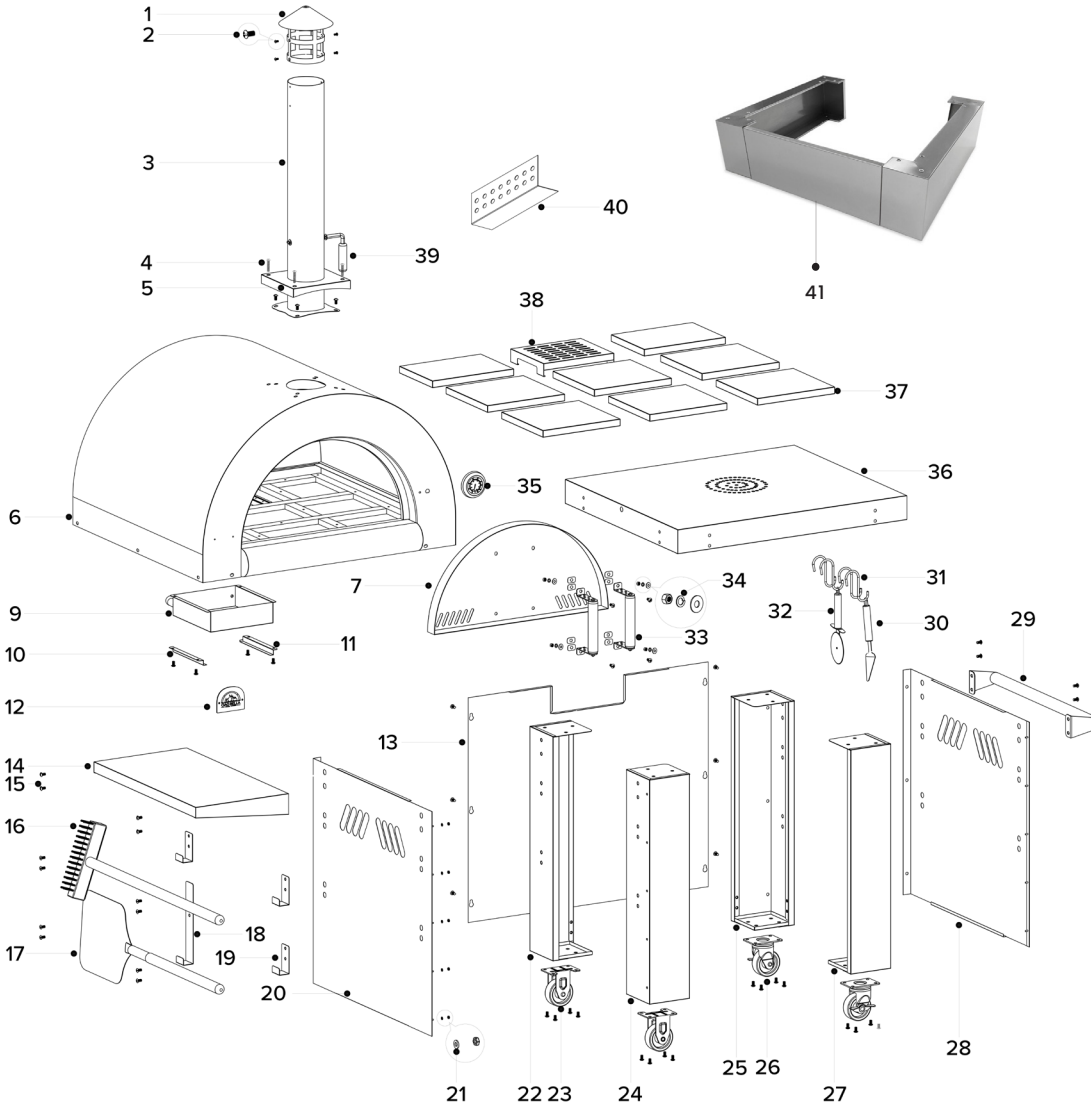

No.	Parts name
1	chimney top
2	chimney top hardware
3	chimney
4	chimney b. hardware
5	chimney bottom
6	oven
7	door
9	ash pan
10	ash support 1
11	ash support 2
12	emblem
13	back panel
14	side shelf
15	side shelf hardware
16	oven broom
17	pizza peel
18	short "L" hooks
19	long "L" hooks
20	left panel
21	left panel hardware
22	back left leg
23	rigid caster
24	front left leg
25	back right leg
26	caster with brake
27	front right leg
28	right panel
29	handle
30	pizza server
31	"S" hooks 1
32	cutting wheel
33	door handles
34	door handles hardware
35	thermometer
36	bottom
37	pizza stones
38	ash cover
39	chimney handle
40	log holder
41	8" riser

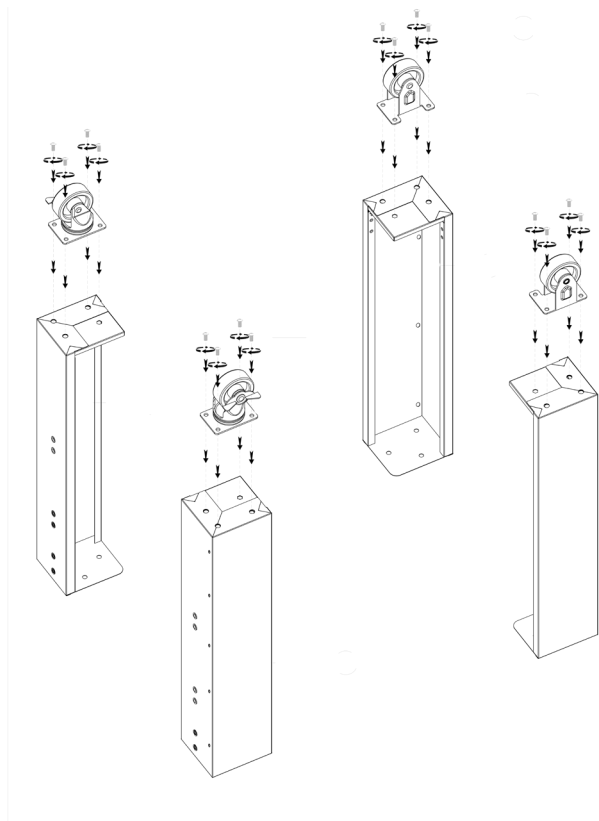

Assemble your brand new oven with the following steps:

1. Fasten casters to legs. Make sure swivel casters w/ brakes are both on the right or left side of the unit.

 BE SURE TO HAVE THE PRE DRILLED ACCESSORY HOLES FACING TO THE SIDE OF THE OVEN STAND [NOT THE FRONT OR BACK] TO INSTALL ACCESSORY HOOKS LATER ON.

2. Fasten legs on the oven body with 12pcs of 1/4" * 15mm screws. Install the bottom shelf and side panels with the 16pcs of 1/4" * 15mm screws.

 THE BOTTOM SHELF IS A RECTANGULAR SHAPE. WHEN ASSEMBLING THE BOTTOM SHELF - BE SURE THE LONGER LENGTHS OF THE SHELF ARE THE FRONT AND BACK OF THE OVEN, AND THE SHORTER LENGTHS ARE AT THE SIDES.

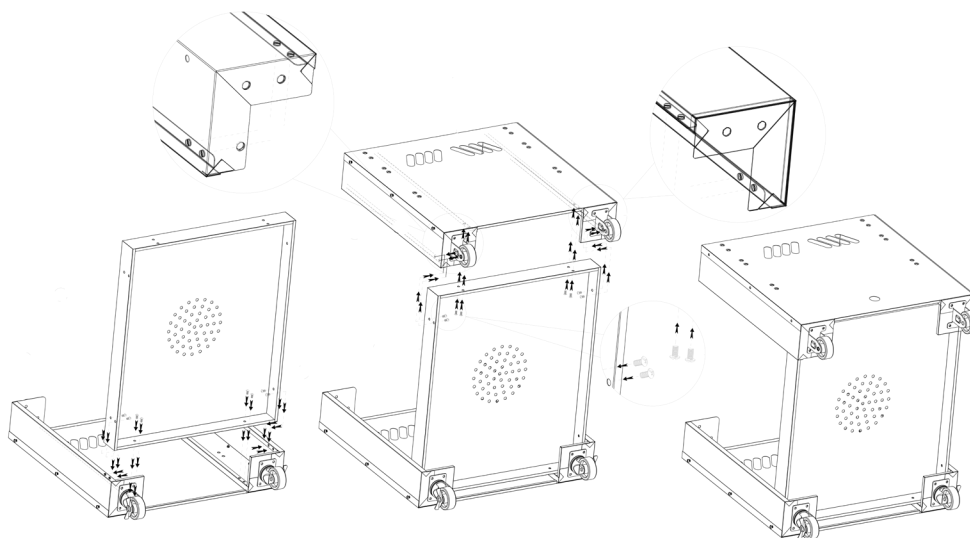

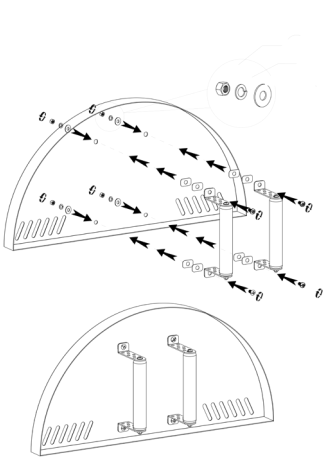

3. Install the door handles with 4 pcs of 1/4"*15mm screws + insulation mat + flat washer + spring washer + 1/4" bolts. Don't place door on oven until your finish step.

NOTE: DISREGARD DOOR WOBBLE. THE DOOR HAS BEEN MANUFACTURED TO ACCOMMODATE HEAT EXPANSION HENSE WHY IT WOBBLER. ORDER OF INSTALLATION — INSULATION MAT MUST BE PLACED BETWEEN DOOR HANDLES + DOOR TO PREVENT HEAT TRANSFER.

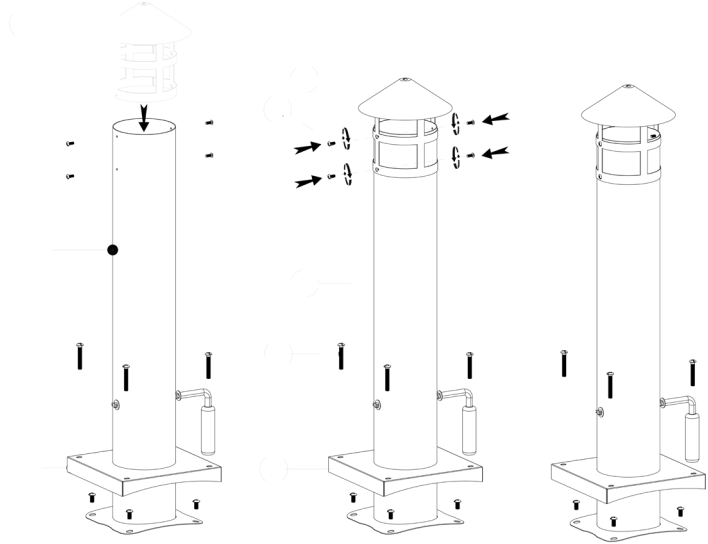

4. Install chimney cap with 4pcs of 5/32"*10mm screws.

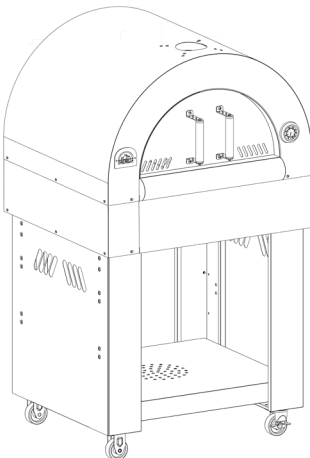

5. Install 8" Riser

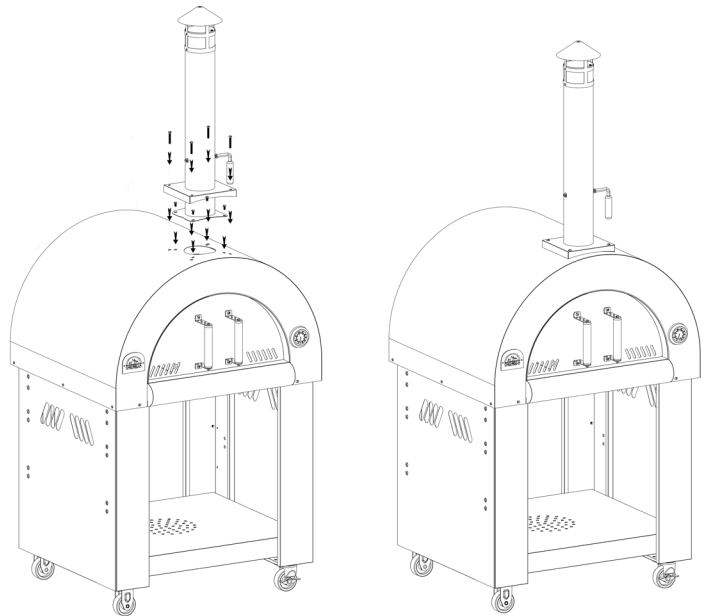

6. Install chimney with 4pcs of 1/4"*15mm screws.

7. Install chimney box with 4pcs of 1/4" 30m screws.

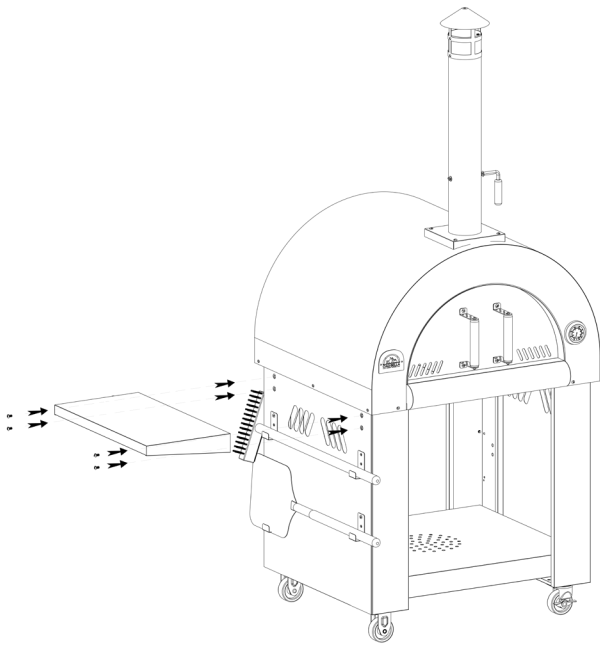

8. Install shelf and right handle with 8pcs of 1/4"*15mm screws.

OPTIONAL: CAN BE ASSEMBLED WITH SHELF ON RIGHT + HANDLE ON LEFT.

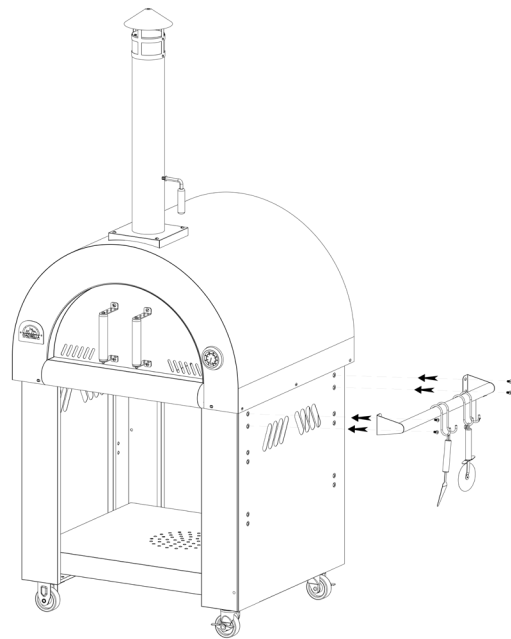

9. Install 3pcs of "L" short hooks and 1pc of long "L" hook with 8pcs of 1/4" *15mm screws.

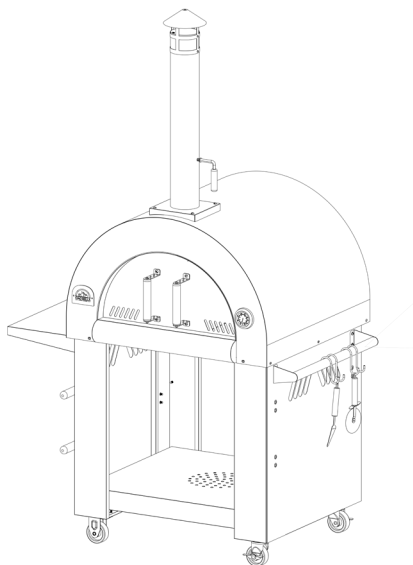

10. Hang 4pcs of "S" hooks on the handle.

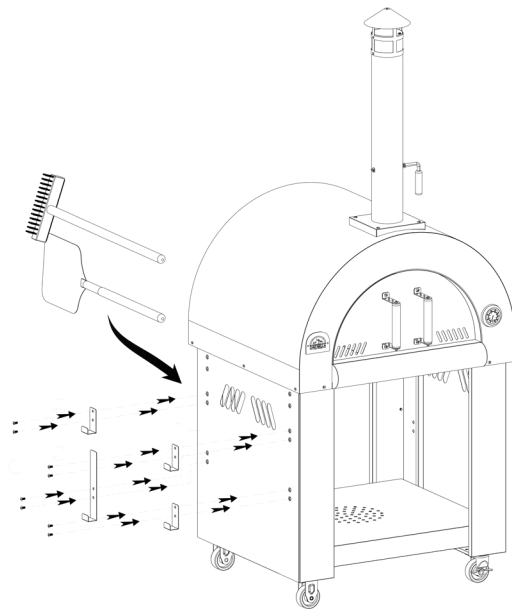

Your oven is ready for use. Enjoy!

Getting Started

Carefully unpack your Wood-fired Outdoor Oven, it's not too heavy, but use two people to lift it out of the box. Be sure to place the Outdoor Oven on a noncombustible Level Surface. Remove all the protective film and discard. Assemble the pizza oven according to the instruction.

 **SEASON THE OUTDOOR OVEN PRIOR TO USE. BURN ONE TIME TO ALLOW THE THERMOMETER TO REACH 300°F AND LET THE FIRE DIE OUT. ONCE YOU BRING THE TEMPERATURE BACK DOWN TO 100°F YOU CAN START YOUR SECOND BURN UP TO 500°F OR LESS [AND COOK AT THIS TEMP FOR THE FIRST TIME]. THIS WILL COMPLETE COOKING YOUR SEASONING.**

THE ART AND SCIENCE OF WOOD-FIRED COOKING

Cooking in your Outdoor Oven is much like using the oven in your home. You will quickly learn how to regulate the temperature, use different woods for flavor, and be amazed at how good the food tastes. Anyone can bake delicious pizza and bread, roast meat and vegetables, grill fish and seafood, and create mouthwatering desserts.

The Cooking Stone and Dome of your Outdoor Oven give off radiant heat from all sides, creating a natural convection that bakes everything to perfection, while the fire on the side brings out a unique crisp and smoky taste. Any variety of oven-safe metal, ceramic or glass pan can be used to cook in your Outdoor Oven.

 **KEEP OVENWARE AWAY FROM FLAME AND DON'T USE IN TEMPERATURES OVER 700°F.**

CHOOSING YOUR WOOD

Use only dry hardwood such as oak and beech. Avoid resinous wood such as pine or spruce. Never use treated lumber.

 **IF THE WOOD PRODUCES A LOT OF BLACK SMOKE, IT IS GENERALLY AN INDICATION YOU ARE USING THE WRONG TYPE OF WOOD. WE RECOMMEND TO ONLY USE HARDWOOD SUCH AS OAK, SUGAR MAPLE, ASH.**

FIRING UP YOUR OVEN

Your Outdoor Oven will bring years of enjoyment and countless delicious dishes once you have mastered the art of building and maintaining a fire that creates an evenly distributed, high-temperature Cooking Stone.

 **INVEST IN A LASER THERMOMETER TO SHOW YOU THE EXACT TEMP INSIDE YOUR OUTDOOR OVEN.**

 **WIPE DOWN OVEN DOME TO REMOVE DEBRIS (E.G. TREE SAP, BIRD DROPPINGS) BEFORE EACH USE. THIS IS HIGHLY RECOMMENDED FOR CUSTOM PAINTED OVENS TO PRESERVE COLOUR INTEGRITY.**

Start the fire in the Outdoor Oven approximately one hour before cooking. Split wood into small pieces about 10" long by 1/2" thick. The maximum loading is 3.5 KG. Using kindling and newspaper, start a match lit fire in the center of the Cooking Stone. Continue to feed the fire with two or three larger pieces until it becomes well established. At this point, put the fire to the left side of the Outdoor Oven using the Ash Sweep. Tip: it doesn't take much wood to bring the Oven to 650°F on the thermometer.

Close the Outdoor Oven door, vented enough to keep the flame burning, and continue to add wood as needed. The flame will reach the top of the dome and curve around to the other side; this is normal, just make sure the flames don't come out of the Outdoor Oven opening. The goal is for the Cooking Stone and Dome to absorb the heat.

Once the thermometer reaches between 600°F-650°F you are ready to start cooking.

High Temperature Cooking: When the Oven Stone is

between 550°F-625°F, you are at a perfect temperature to cook pizza. Pizzas are placed with the 11.5" Square Peel on the Cooking Stone and take less than 3 minutes. Remember to rotate the pizza, with the 8.5" Round Peel, to ensure even cooking. Tip: A great trick to check if your pizza crust is fully baked, is to lift your pizza (while cooking) with the 8.5" Round Peel. If the pizza folds over the sides of the peel, the crust is not fully cooked.

Medium Temperature Cooking: When the Cooking Stone is between 450°F-550°F, you are at a good temperature to roast meat, vegetables, fish and seafood. Depending on the dish, you may want to cover it initially to allow it to cook fully before removing the cover for browning. You will also want to rotate the pans and roasts, alternating the side facing the fire.

Low Temperature Cooking: When the Cooking Stone is between 325°F-425°F, you are at a good temperature for baking breads, pies and desserts. Generally this is easiest to do after all of your cooking is complete, and by removing all the embers from the Outdoor Oven. Keep in mind that the Outdoor Oven will have to be pre- heated well in order to retain enough heat for cooking without fire. So make sure the Cooking Stone is 500°F or higher for at least 15 minutes before removing all the embers.

 **ALWAYS WEAR BARBECUE MITTS WHEN COOKING OR ADJUSTING THE VENTS AS WELL AS WHEN USING A CHIMNEY STARTER. WHEN PREPARING FOOD, ADJUSTING THE VENTS, PLACING WOOD AND USING THE THERMOMETER OR LID ALWAYS WEAR BARBECUE MITTS. PLEASE USE GRILL GLOVES (HEAT PROTECTED), THE GRILL GLOVES MUST BE IN ACCORDANCE WITH THE DIRECTIVE 89/686/EEC (FOR EXAMPLE: PERFORMANCE LEVEL 2 FOR RESISTANT FOR CONTACT HEAT (IN ACCORDANCE TO DIN EN 407)**

CLEANING THE OVEN

Once the Outdoor Oven is cold, use the 11.5" Square Peel and the Ash Sweep to brush the Cooking Stone to remove all the ash and debris. Never extinguish the fire with water. Never use chemical cleaners. If you wish to clean the surface of your Cooking Stone, a damp cloth works best.



ENJOY YOUR BRAND NEW OVEN.

Shop accessories
from our website.



Visit our YouTube channel
for recipes:

 [www.youtube.com/
@ciobellapizzaovens](http://www.youtube.com/@ciobellapizzaovens)

**Don't forget to share posts and stories
on Instagram and Facebook.**

info@ciobellapizzaovens.com
ciobellapizzaovens.com



CIAO.